

Level Switch

FS-3

INSTRUCTION MANUAL

Thank you for purchasing HANYOUNG product.
Please check whether the product is the exactly same as you ordered.
Before using the product, please read this instruction manual carefully.
Please keep this manual where you can view at any time

HEAD OFFICE

HANYOUNGNUX CO.,LTD
1381-3, Juan-Dong, Nam-Gu Incheon, Korea.
TEL:(82-32)876-4697
FAX:(82-32)876-4696
http://www.hynux.net

INDONESIA
FACTORY

PT. HANYOUNG ELECTRONIC INDONESIA
Jl. cempaka blok F16, No.02 Delta Silicon II
Cikarang Bekasi Indonesia
TEL : 62-21-8911-8120~4
FAX : 62-21-8911-8126



Safety information

Before using the product, please read the safety information thoroughly and use it properly.
Alerts declared in the manual are classified to Danger, Warning and Caution by their criticality

	DANGER	DANGER indicates an imminently hazardous situation which, if not avoided, will result in death or serious injury
	WARNING	WARNING indicates a potentially hazardous situation which, if not avoided, could result in death or serious injury
	CAUTION	CAUTION indicates a potentially hazardous situation which, if not avoided, may result in minor or moderate injury

WARNING

- If the user use the product with methods other than specified by the manufacturer, there may be bodily injuries or property damages.
- If there is a possibility of an accident caused by errors or malfunctions of this product, install external protection circuit to prevent the accident.

CAUTION

- Do not touch or connect any undesirable conductive part to input-output terminal since there is a possibility of electric shock.
- Please do not supply the overload larger than the rating to the output contact of the relay.
- The wire length should be as short as possible from the instrument to the electrode.
- Please use a thick wire as possible between the instrument and the electrode.
- Please do not put the input signal wires and other load wires in the same conduit.
- If the input wire is longer, please use the shielded wire.
- Please avoid installing a controller in a place where there is steam, dust, corrosive gas and water splash.
- Please install AC power lines in a metal conduit with separating input sensor signal wires.
- Never disassemble, modify, or repair the product. There is a possibility of a malfunction, an electric shock, or a risk of fire.

※ Please follow the above contents described in the safety information if not it may lead to a product failure.

Specification

Model	FS-3 A (high sensitivity)	FS-3 A (low sensitivity)
Power supply Voltage	110 V a.c / 220 V a.c 50/60 Hz	
Allowable voltage fluctuation range	± 10 % of the power supply voltage	
Voltage between the electrodes secondary voltage	24 V a.c	8 V a.c
Power consumption	Approx. 3.2 VA	
Response time	Max 80 ms when operating, max 160 ms when returning	
Operation resistance between electrodes	0 - approx. 27 kΩ	0 - approx. 7 kΩ
Return resistance between electrodes	approx. 38 kΩ - ∞ Ω	approx. 15 kΩ - ∞ Ω
Control output	Relay contact output (1c): 250 V a.c 5 A (resistive load)	
Insulation resistance	100 MΩ min (with 500 V d.c mega) electric conduction part and exposed non-charged metal part	
Dielectric strength	2000 V a.c 50 - 60 Hz for 1 min (between the two poles recharging part terminal)	
Vibration resistance	10-55 Hz (for cycle 1 min) Peak amplitude for 2hrs each in X, Y and Z direction 0.76 mm	
Shock resistance	300 %	
Life expectancy	Mechanically more than 5 million times (relay type), electrically more than 500 thousand times (load resistance)	
Ambient temperature	-10 ~ 50 °C (with no icing or condensation)	
Ambient humidity	35 ~ 85 % R.H.	

Dimension

[Unit : mm]

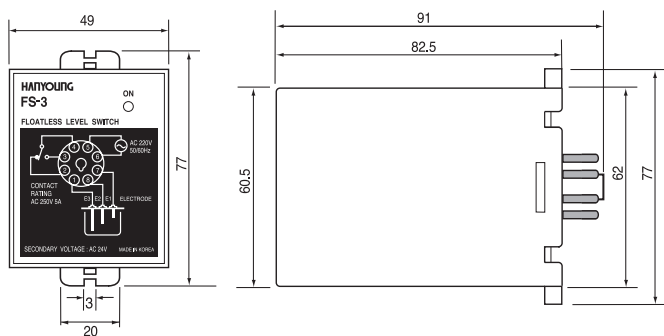

Connections

External connection

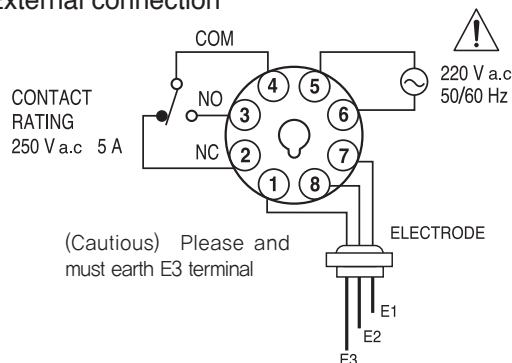

Internal connection

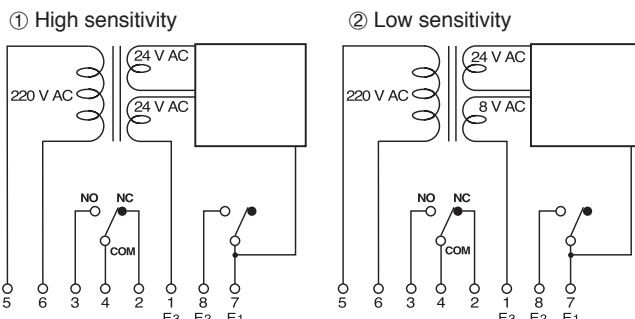

Regarding the connection of load

- Attaching the surge observer at the each and of inducible load (motor, solenoid and etc) just like an image given on the right side will restrain noise to occur

